

# 250W Peak V-Band Liquid-Cooled Antenna Mount High Power Amplifiers



## FEATURES

- *250 watts V-band peak TWT power*
- *Commercial frequencies between 47.2 and 51.4 GHz (optional 47.2 to 52.4 GHz)*
- *Liquid-cooled for simpler hub installation*
- *Includes linearizer*
- *Complete RS-232/422/485 ethernet interface*
- *-40°C to +60°C ambient*

The **XTDL-250QV2** and **XTDL-250QV2E** are compact, self contained antenna mount power amplifiers designed for low cost installation and long life. The unit is liquid cooled instead of air-cooled, offering users ambient noise reduction, reduced heat load in hubs, and superior gain stability over temperature. Air conditioning in the hub is also simplified or eliminated.

The amplifiers features high RF efficiency which enables a smaller, lighter amplifier with the ability to operate at up to 60 deg C ambient temperatures.

Comtech Xicom has developed proprietary features to improve performance and life including an automatic bias control system which extends TWT life by maintaining constant beam current over time and a precise system for matching linearizer performance to a specific tube over a wide range of operating conditions maximizing useable linear power.

Optional integrated block upconverters (BUC) are available. They can be ordered with an integral 10 MHz reference module for independent operation or with external 10 MHz input for phase lock to GPS or other system clocks.

The amplifier is equipped with an internal 1:1 switch control capable of driving an input and output switch for redundancy. Rack mountable controllers are also available.



# PERFORMANCE SPECIFICATION

Parameters	XTDL-250QV2	XTDL-250QV2E
FREQUENCY RANGE	47.2 to 51.4 GHz	47.2 to 52.4 GHz
OUTPUT POWER		
Traveling Wave Tube		250W (54.0 dBm) PK
Rated Power @ Amplifier Flange		80W (49.0 dBm)
GAIN		
Large Signal (minimum)		60 dB
Small Signal (minimum)		60 dB
Attenuator range (0.1 dB steps)		20 dB
Maximum SSG Variation Over		
Any 500 MHz		2.0 dB maximum
Full Band	4.0 dB (maximum)	5.0 dB (maximum)
Slope (maximum)		± 0.02 dB/MHz
Stability, 24 hr. (maximum)		± 0.25 dB
Stability, Temperature (maximum)		± 1.0 dB at any frequency
NOISE POWER RATIO (NPR)		19 dBc @ P <sub>LINEAR</sub>
HARMONIC OUTPUT (maximum)		-60 dBc
AM/PM Conversion (maximum)		2°/dB @ P <sub>IN</sub>
NOISE POWER (maximum)		
Transmit Band		-70 dBW/4 kHz
Receive Band (<21.2 GHz)		-150 dBW/4 kHz
GROUP DELAY (maximum)		
Bandwidth		Any 60 MHz
Linear		0.01 nS/MHz
Parabolic		0.005 nS/MHz <sup>2</sup>
Ripple		0.5 nS/Pk-Pk
RESIDUAL AM NOISE (maximum)		-50 dBc to 10 kHz -20 (1.5 + logf) dBc 10 to 500 kHz -85 dBc above 500 kHz
PHASE NOISE (maximum)		15 dB below IESS phase noise profile AC fundamental -50 dBc Sum of all spurs -45 dBc
VSWR		
Input (maximum)		1.3:1
Output (maximum)		1.3:1

# BLOCK DIAGRAM

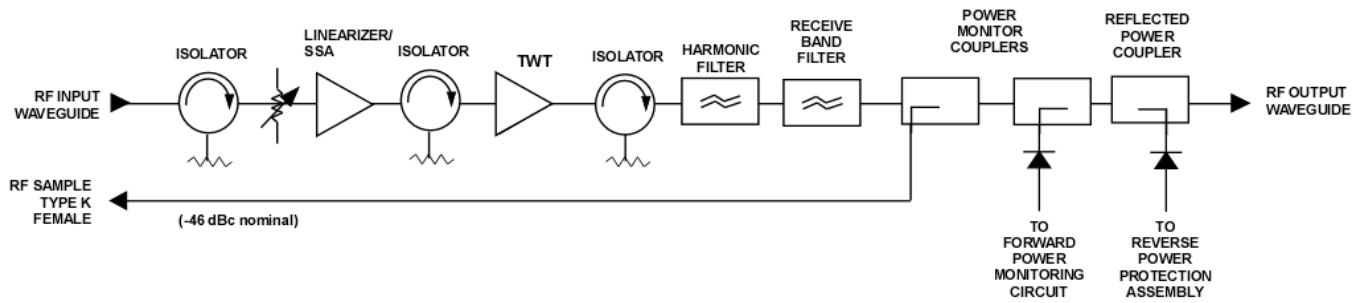

# OUTLINE DRAWING

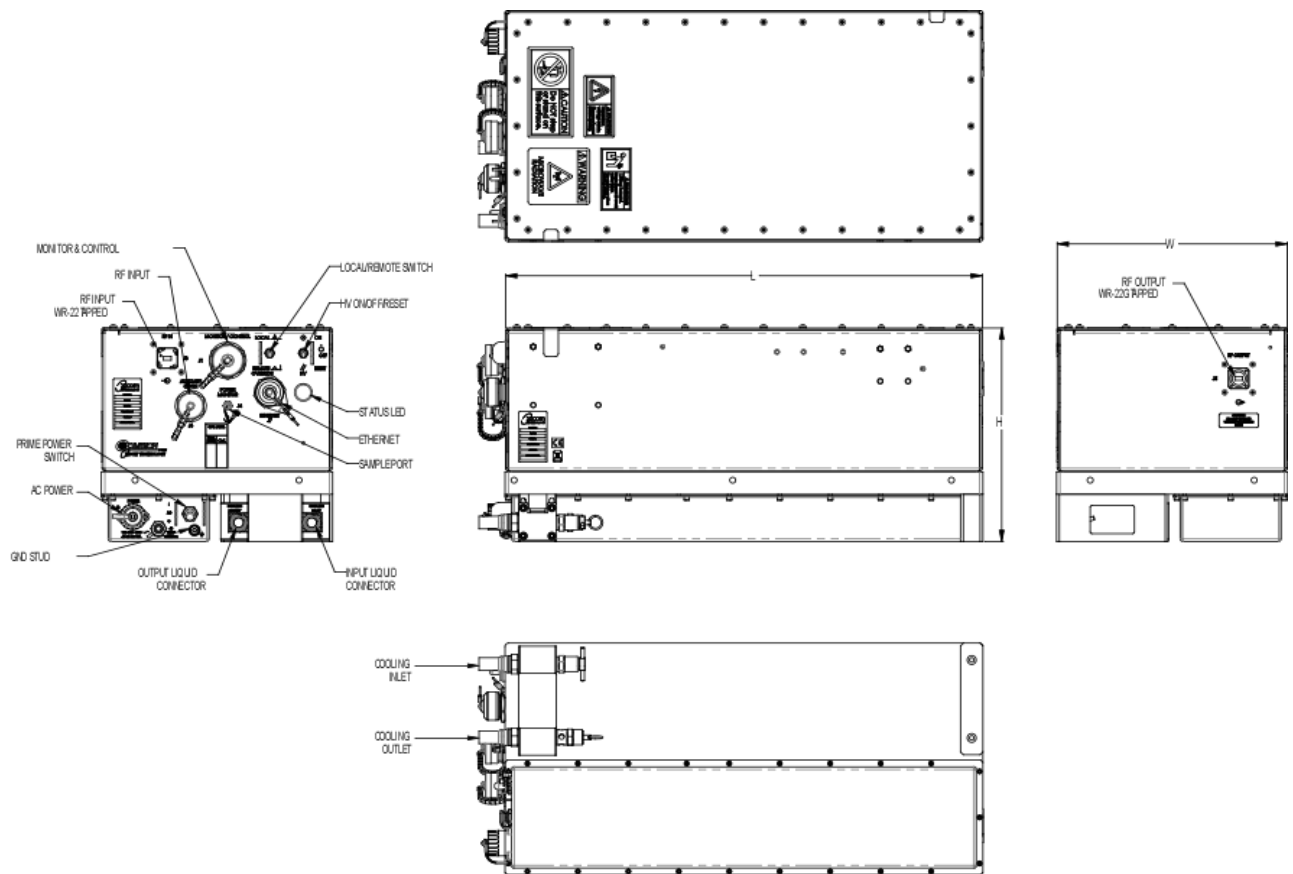

DIMENSIONS		
	INCHES	CENTIMETERS
L	20.06	50.80
H	9.50	24.13
W	10.25	26.04
Typical Weight = 58 lb (26.31 kg)		

**XTDL-250QV2 / XTDL-250QV2E**



## PRIME POWER

100 to 260 VAC  
6 Hz, Single Phase  
900 VA Typical  
0.95 Min. Prime Power Factor



## ENVIRONMENT

NONOPERATING TEMPERATURE RANGE	-50°C to +70°C
OPERATING TEMPERATURE RANGE	-40°C to +60°C
HUMIDITY	Up to 100% Condensing
ALTITUDE	10,000 feet MSL maximum with standard adiabatic derating
SHOCK AND VIBRATION	Normal Transportation
COOLING	Liquid Cooled

## INTERFACE

Type	Function	
LOCAL CONTROL	Prime Power ON/OFF	Local/Remote
	Power Supply ON/OFF	HV ON/OFF
LOCAL STATUS	Tri-Color LED:	
	Fault: Red	Standby: Continuous Amber
	HV ON: Green	
REMOTE CONTROL	HV ON/OFF	RF Inhibit (HV OFF)
	RF Attenuation	Fault Reset
	Heater Standby	Constant Power
REMOTE STATUS	HV ON	Heater/Beam Hours
	RF Output Power	Fault Identification
	Reflected Power	TWT Temperature
	Filament Time Delay	Helix Current
	Helix Voltage	
DISCRETE STATUS	Summary Fault (2X Form C Dry Contact Closure)	
RF MONITOR PORT	-50 dB Coupling Value (nominal)	
INTERFACE	Serial 232/422/485 Ethernet	

## OPTIONS

- WR-19 Waveguide
- Remote External Controller
- 1:1, 1:2, 1:N Redundancy
- Phase Combined

## Headquarters

Comtech Xicom Technology, Inc.  
3550 Bassett Street  
Santa Clara, CA 95054  
USA

Phone: +1-408-213-3000

Fax: +1-408-213-3001

email: [sales@xicomtech.com](mailto:sales@xicomtech.com)

Web: [www.xicomtech.com](http://www.xicomtech.com)

## European Sales Office

Comtech Xicom Technology Europe, LTD  
4 Portland Business Center  
Manor House Lane  
Datchet  
Berkshire SL3 9EG  
United Kingdom

Phone: +011 44 (0) 1753 549 999

Fax: +011 44 (0) 1753 549 997

email: [sales@xicomeurope.com](mailto:sales@xicomeurope.com)

Web: [www.xicomtech.com](http://www.xicomtech.com)

## Singapore Sales Office

Comtech Xicom Technology  
150 Cecil Street  
#08-02  
Singapore 069543

Phone: +011 65 6325 1953

Fax: +011 65 6325 1950

email: [asiasales@xicomtech.com](mailto:asiasales@xicomtech.com)

Web: [www.xicomtech.com](http://www.xicomtech.com)